

SERIE / MODEL EMF-N □□□/CL  
CODICE / CODE 12.04.□□□.03

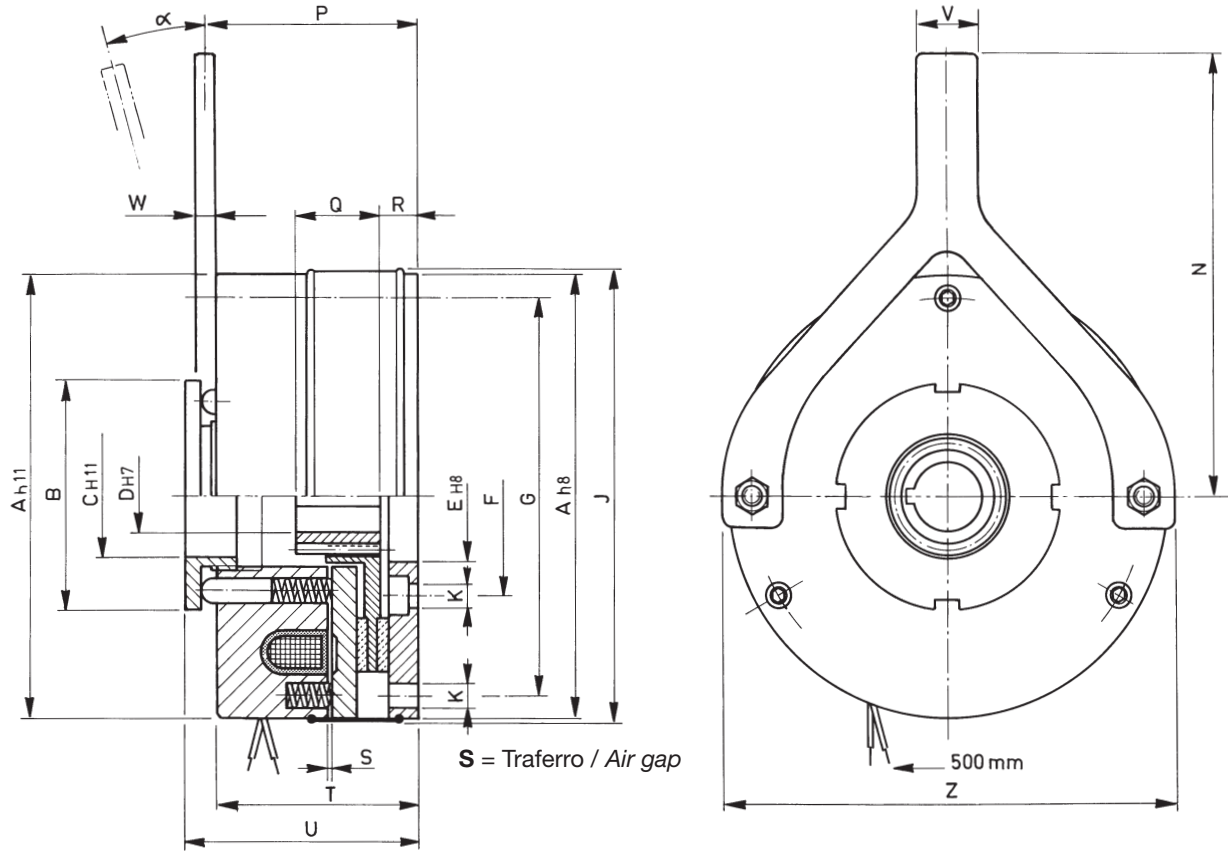

Bobina non eccitata / Coil without excitation energy = Freno bloccato / Locked brake  
Bobina eccitata / Energized coil = Freno libero / Free brake

□□□	Momento Torque Ms (Nm)	Giri/1' R.P.M. limit max.	Tempi inser. Build up time ms.	Tempi disin. Decay time ms.	WATT		Peso Weight kg
					20°	120°	
083	5	6000	55	110	18	13	0,9
100	10	5000	60	130	22	15	1,5
125	20	4000	75	165	30	22	2,4
145	40	3400	88	180	38	27	4,1
160	80	3000	105	200	48	34	5,6
185	100	2600	140	225	54	39	8,5
215	180	2200	200	280	64	46	12,8
250	300	2000	260	310	135	100	20
296	440	1600	340	380	92	68	32

□□□	A	B	C	D		E	F	G	J	K	N	P	Q	R	S	T	U	V	W	Z	α
				min.	max					n° x Ø							max				
083	83	42	19	8	12	20	30	72	85	3 x 4,5	110	41	18	6	0,2	37,5	44	8	8	84	5°
100	102	52	24	10	15	30	45	90	105	3 x 5,5	130	45	20	7	0,2	42,5	49	15	4	104	5°
125	125	63	35	10	24	40	56	112	130	3 x 6,5	155	56	20	9	0,2	53	61	15	5	128	5°
145	145	74	40	14	28	45	62	132	148	3 x 6,5	180	61	25	12	0,3	58	68	15	5	148	6°
160	160	84	52	14	34	55	74	145	163	3 x 9	190	70	30	14	0,3	67	77	22	6	166	6°
185	185	98	52	15	38	65	84	170	190	3 x 9	195	73	30	14	0,3	70	81	22	6	190	8°
215	215	108	62	20	48	75	100	196	220	6 x 9	240	86	35	15,5	0,4	82	95	28	8	222	10°
250	250	138	73	25	60	90	120	230	255	6 x 11	300	94	40	17,5	0,4	90	112	28	8	258	10°
296	296	166	95	30	70	120	150	278	305	6 x 11	350	105	50	18,5	0,5	101	122	30	8	308	12°